



6 to 26 GHz Frequency Converter

SC2426 | Microwave Frequency Converter

Product Brief

Summary

The SC2426 RF Converter is a stand-alone platform for use in the 6 to 26 GHz range.

The module is designed to interface directly with software-defined radios, such as those commonly implemented using Analog Device's Mixed-Signal Front-End (MxFE), National Instruments USRP, or similar Software Defined Radio.

Up to four modules can be combined in parallel to create complex MIMO applications.

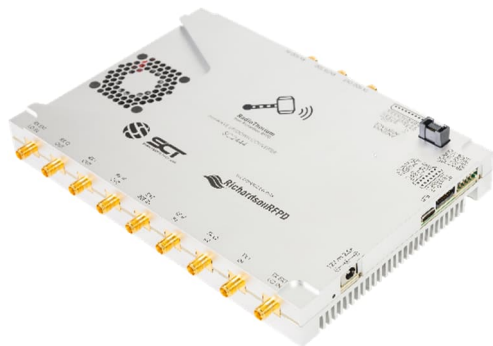

SC2426 – RF Converter Module

Description

Power is provided via a 12-volt wall cube which is included with the Development Kit. An embedded fan and temperature monitoring are integrated into the unit to manage heat.

Control of the module is provided via the USB, UART, or SPI interfaces. Most users will find it convenient to control the module using the console interface over USB. Alternatively, embedded controllers may access the UART or SPI interfaces available on the external Control Ports.

Two API protocols are available. The first is ASCII-based, and its commands follow the SCPI structure as defined in IEEE 488.2. The second is a binary protocol, targeted at embedded control applications where speed and timing are critical. Both protocols are detailed in an API Specification.

Up to 4 units can be combined in a vertical stack to create a complex 4 x 4 MIMO radio system. In this scenario, the internal control buses are routed to the cascaded modules over the Expansion Port. In this manner, API commands sent on the primary unit, can be redirected to the downstream modules. This eliminates the need for multiple controllers and simplifies timing and synchronization between units.

Module addresses are set using a DIP switch on the Configuration Port.

Secondary and External Control Ports are also available. These ports expose Power, SPI, I2C, UART and GPIO that provide users with a convenient method of interfacing to external front-end modules, such as integrated antenna arrays or switched filter banks.

The low-frequency RF inputs include the I/Q, and external LO ports on SMA connectors.

The converter can be used in either Time Division Duplex (TDD) or Frequency Division Duplex (FDD) mode. The RF ports include 3.5mm connectors for the FDD TX and RX functions, in addition to a bidirectional TDD port.

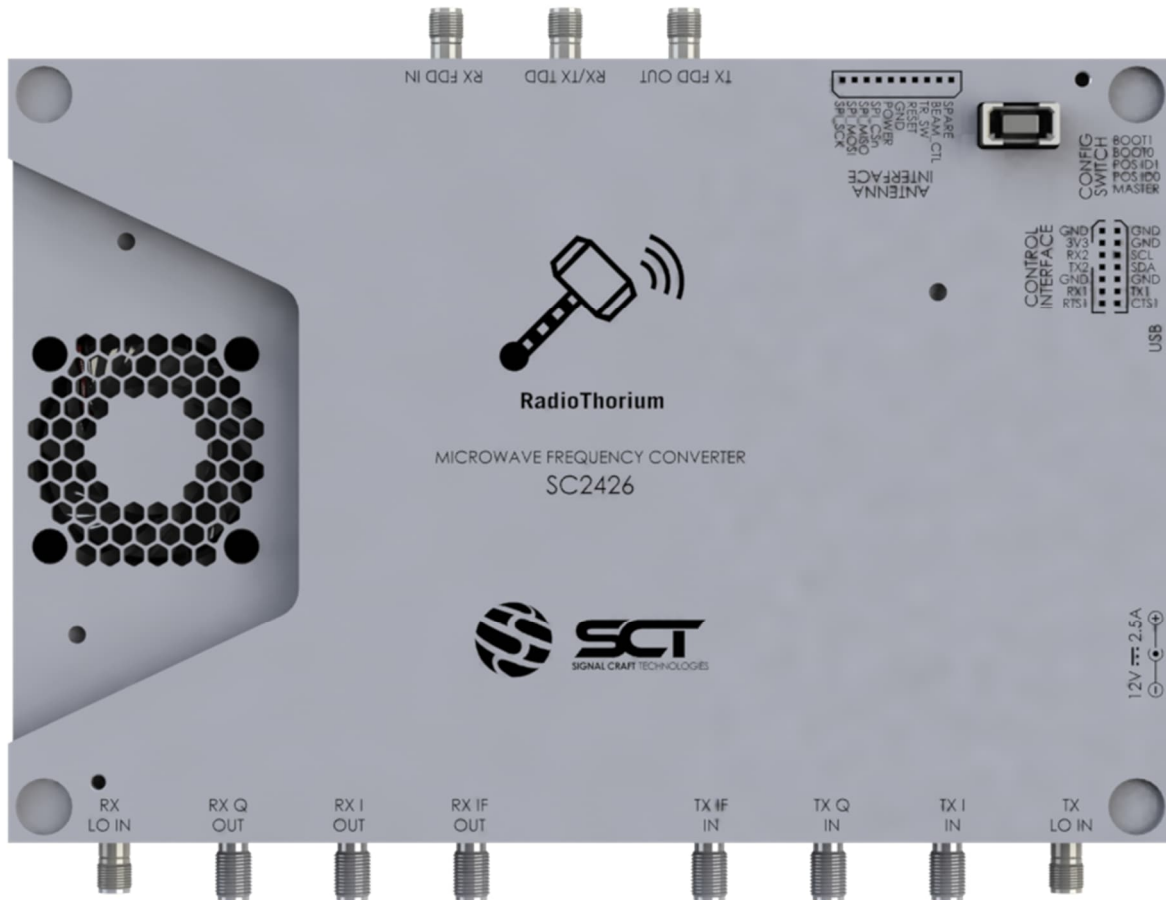

SC2426 Top View

Common Applications

- 5G FR3 Research and Development
- Aerospace and Defense Application Prototyping
- Software Defined Radio Applications
- Advanced Wireless Communications Research

Radio Path – Simplified Block Diagram

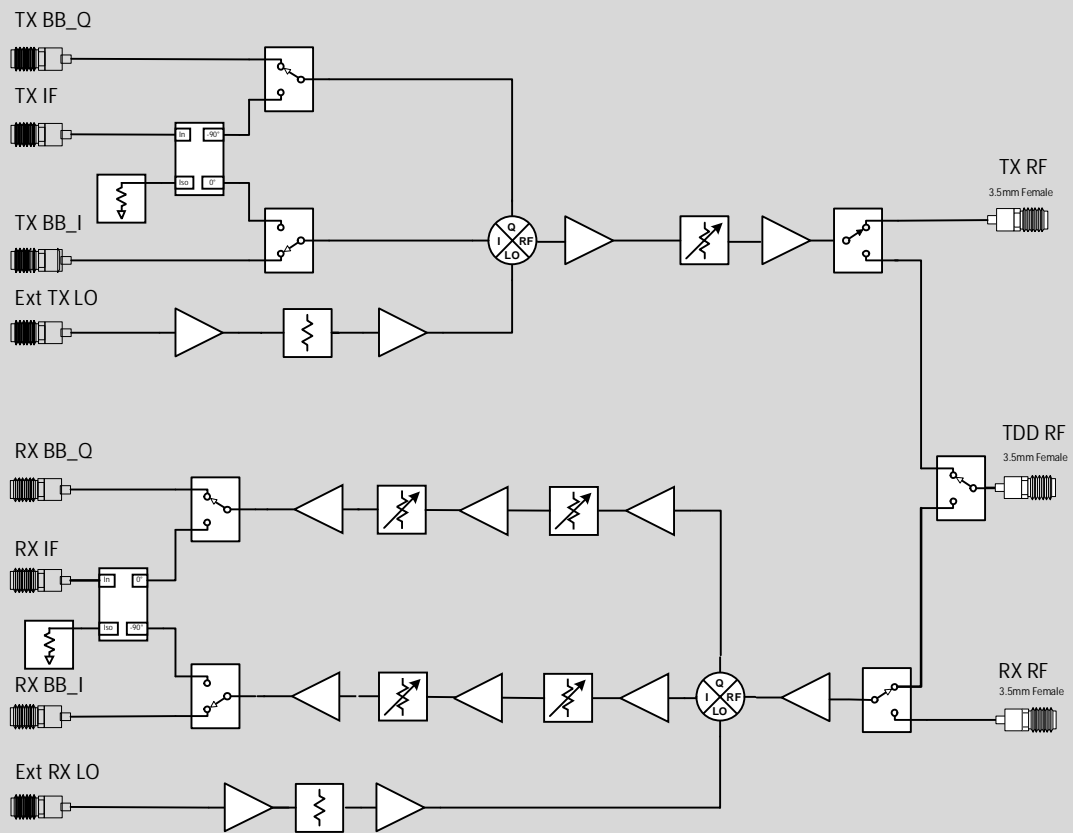

Downconverter Typical Performance

Frequency Response (Gain=Max, IF=4GHz)

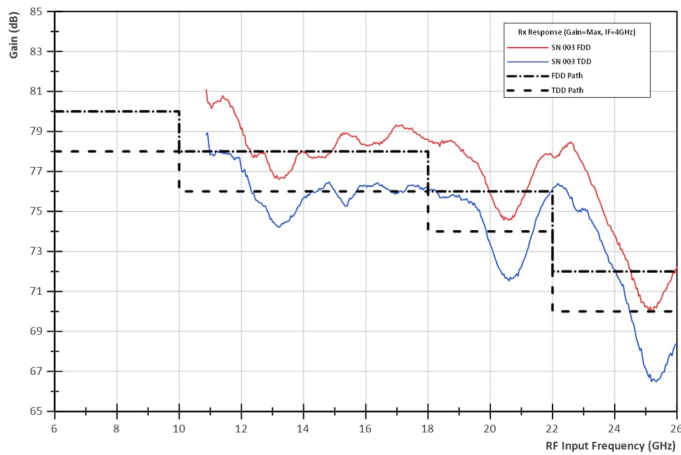

Frequency Response (Gain=Min, IF=4GHz)

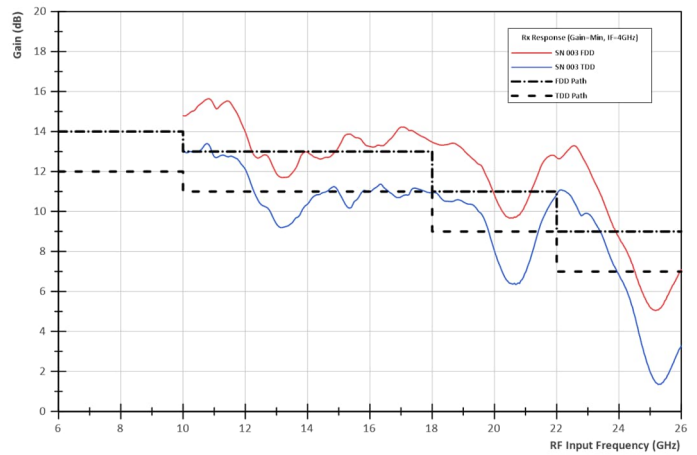

Noise Figure (Gain=Max, IF=4GHz)

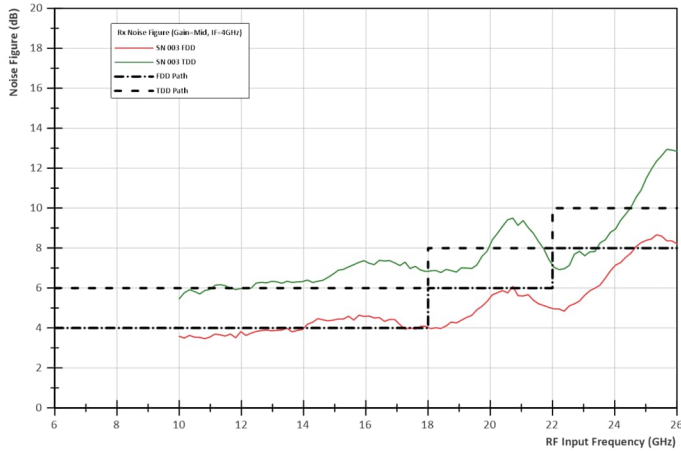

Input P1dB (Gain=Min, IF=4GHz)

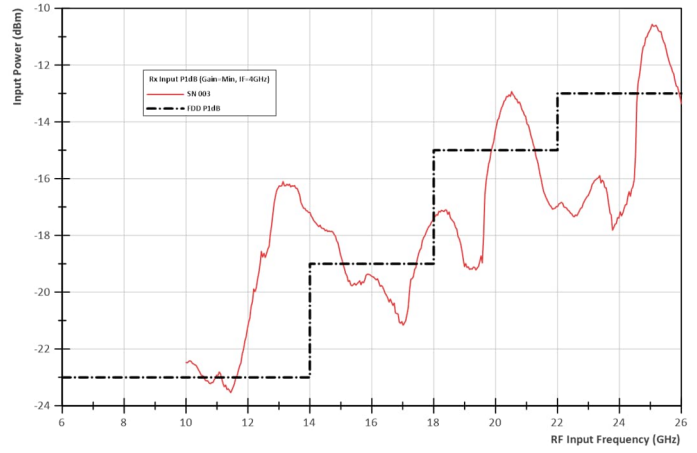

Baseband Frequency Response (Gain=Max, RF=16GHz)

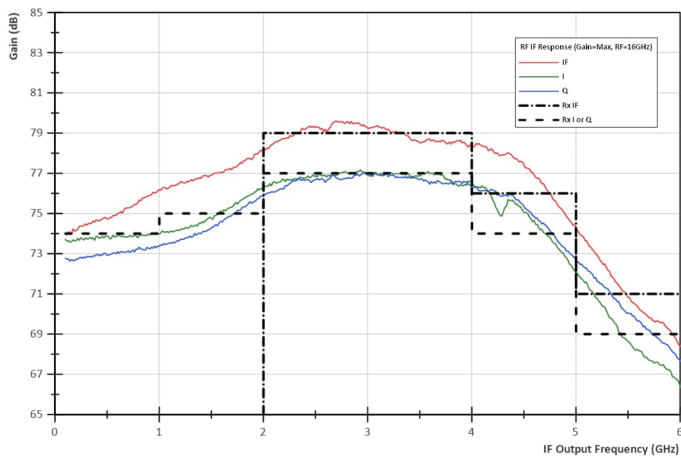

Upconverter Typical Performance

Frequency Response (Gain=Max, IF=4GHz)

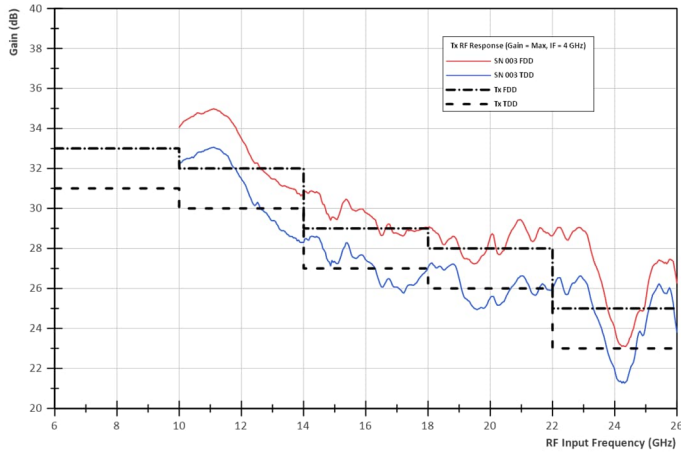

Frequency Response (Gain=Min, IF=4GHz)

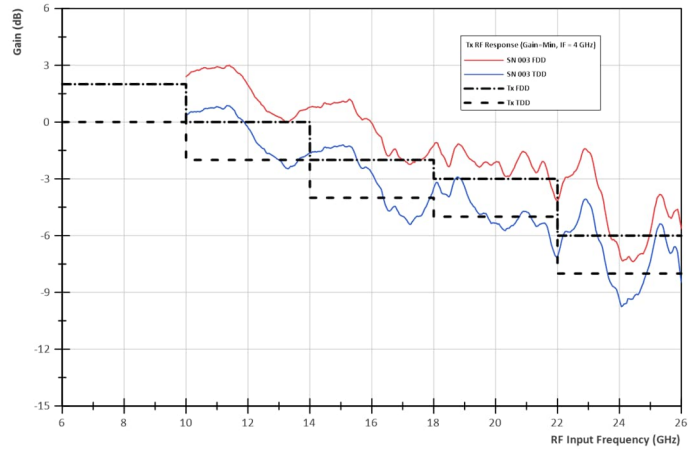

Noise Figure (Gain=Max,Min, IF=4GHz)

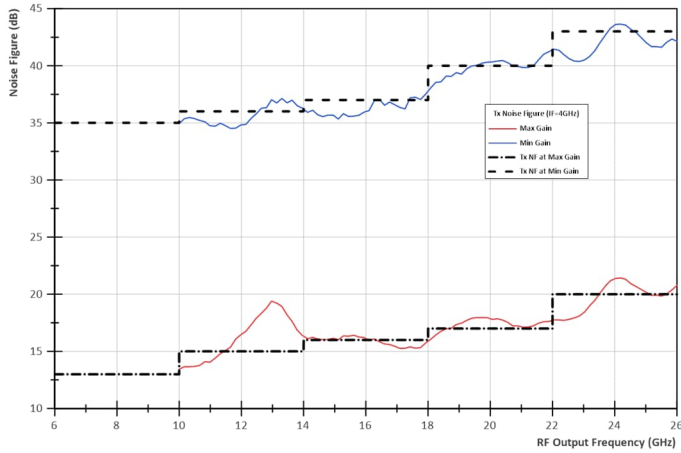

Output P1dB (Gain=Min, IF=4GHz)

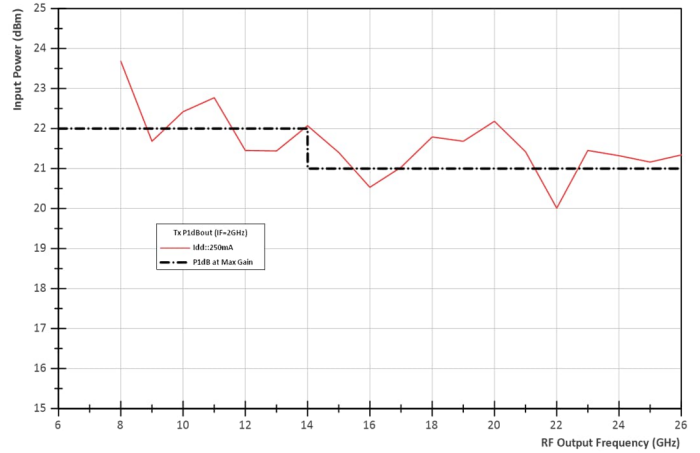

Baseband Frequency Response (Gain=Max, RF=16GHz)

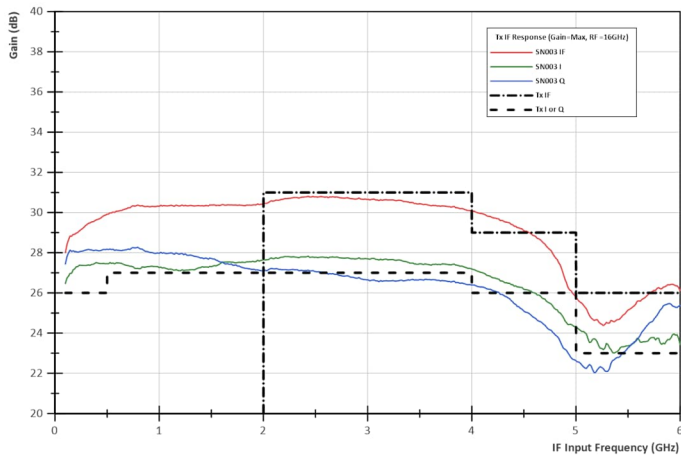

Transmit EVM (Gain=Max, 5G 100MHz, 60 kHz SCS, 256 QAM)

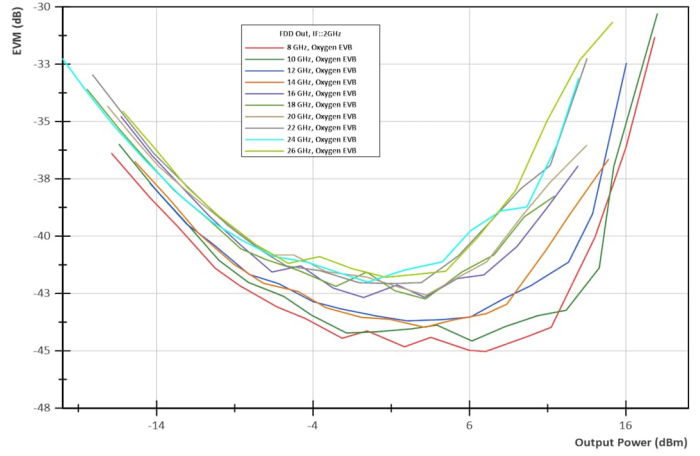

Typical Performance - Summary

Down Conversion (DC) Path

- Input Frequency Range: 6 to 26 GHz
- Maximum Input Power: 0 dBm
- IF Output Range: 2 to 6 GHz
- I/Q Bandwidth: 0.1 to 6 GHz
- External LO: 6 to 26 GHz

Up Conversion (UC) Path

- IF Output Range: 2 to 6 GHz
- I/Q Bandwidth: 0.1 to 6 GHz
- Maximum Input Power: +5 dBm
- Output Frequency Range: 6 to 26 GHz
- External LO: 6 to 26 GHz

DC IF Output Path – Maximum Gain

- Conversion Gain:
 - 80 dB @ 6 GHz
 - 78 dB @ 12 GHz
 - 74 dB @ 18 GHz
 - 72 dB @ 26 GHz
- Gain Control Range: 60 dB in 1.0 dB Steps
- Noise Figure:
 - 4 dB @ 6 GHz
 - 4 dB @ 12 GHz
 - 4 dB @ 18 GHz
 - 8 dB @ 26 GHz
- 1 dB Input Compression Point
 - -65 dBm @ 6 GHz
 - -63 dB @ 12 GHz
 - -63 dB @ 18 GHz
 - -55 dB @ 26 GHz

UC IF Output Path – Maximum Gain

- Conversion Gain:
 - 33 dB @ 6 GHz
 - 32 dB @ 12 GHz
 - 29 dB @ 18 GHz
 - 25 dB @ 26 GHz
- Gain Control Range: 30 dB in 1.0 dB Steps
- Noise Figure:
 - 13 dB @ 6 GHz
 - 15 dB @ 12 GHz
 - 16 dB @ 18 GHz
 - 20 dB @ 26 GHz
- 1 dB Output Compression Point
 - 22 dBm @ 6 GHz
 - 22 dB @ 12 GHz
 - 21 dB @ 18 GHz
 - 21 dB @ 26 GHz

DC IF Output Path – Minimum Gain

- Conversion Gain:
 - 14 dB @ 6 GHz
 - 13 dB @ 12 GHz
 - 9 dB @ 18 GHz
 - 7 dB @ 26 GHz
- Noise Figure:
 - 17 dB @ 6 GHz
 - 18 dB @ 12 GHz
 - 18 dB @ 18 GHz
 - 22 dB @ 26 GHz
- 1 dB Input Compression Point
 - -23 dBm @ 6 GHz
 - -23 dBm @ 12 GHz
 - -15 dBm @ 18 GHz
 - -13 dBm @ 26 GHz

UC IF Output Path – Minimum Gain

- Conversion Gain:
 - 1 dB @ 6 GHz
 - 0 dB @ 12 GHz
 - -3 dB @ 18 GHz
 - -6 dB @ 26 GHz
- Noise Figure:
 - 35 dB @ 6 GHz
 - 36 dB @ 12 GHz
 - 40 dB @ 18 GHz
 - 43 dB @ 26 GHz
- 1 dB Input Compression Point
 - 9 dBm @ 6 GHz
 - 7 dBm @ 12 GHz
 - 5 dBm @ 18 GHz
 - 6 dBm @ 26 GHz



Support

Technical support is available through our website, www.signalcraft.com/support, or by contacting us at support@signalcraft.com.

Warranty

Full one-year parts and labor when used under normal installation and operation conditions. Repair services are available for products no longer covered under warranty.

Ordering Information

Send inquiries to info@signalcraft.com.